

PRINT & APPLY

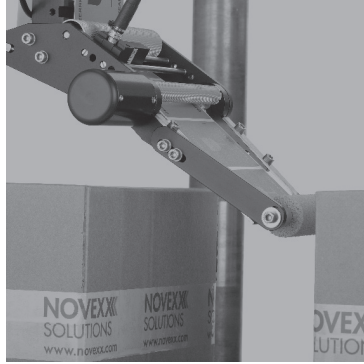

LABELERS

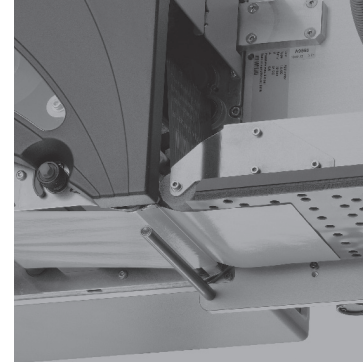

LABEL PRINTERS



COMPLETE SOLUTIONS

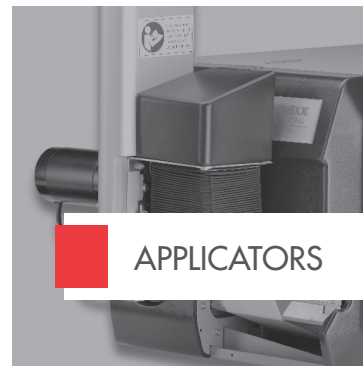
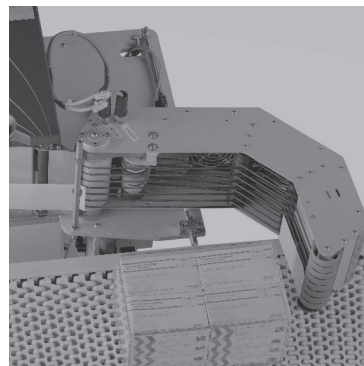

APPLICATORS

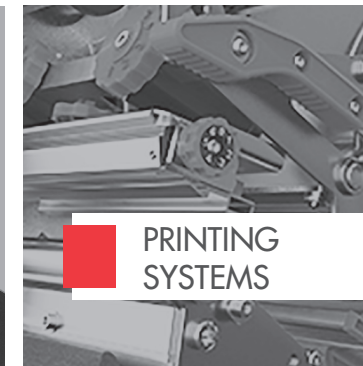
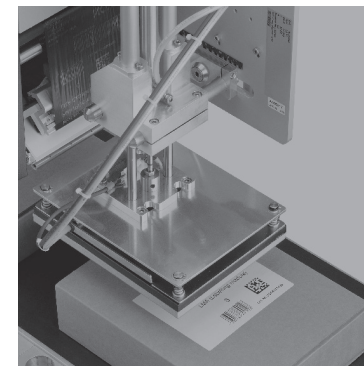

PRINTING SYSTEMS



IDENTIFICATION SOLUTIONS THAT WORK

HARDWARE | SOFTWARE | CONSUMABLES | SERVICE & SUPPORT



DATA MANAGEMENT



LABELS & RIBBONS

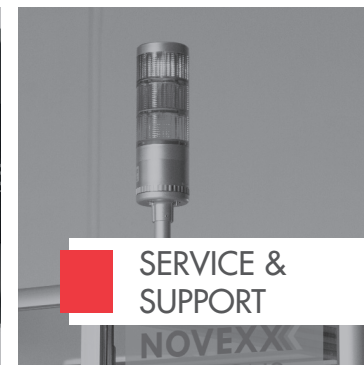

SERVICE & SUPPORT





Print & Apply



XPA 934

The new generation of Print & Apply Systems

- Excellent print results in real time
- Maximum user-friendliness
- Highest flexibility for integration
- 100 % tool-free maintenance
- Web interface for mobile device management
- Robust, industrial housing

Models

XPA 93x

ALX 92x

ALX 73x



Labelers



XLS 2xx

The intelligent industrial Labeler for highest flexibility

- Perfect application of decorative and informative labels
- For demanding 24/7 non-stop use
- Label widths up to 233 mm
- Apply speeds of up to 70 m/minute
- Compact design, easy integration into production lines
- Tandem function for non-stop production
- IP 65 protection against water and dust

Models

XLS 2xx

ALS 30x



Printing Systems



XTO

Thermal Transfer Overprint how it should be

- Direct printing on flexible packaging foil, high print volumes, highest efficiency
- Maximum user-friendliness, tool-free maintenance
- Can easily be combined with our XLS Labelers

Models

XTO

DPM/PEM

DPM / PEM

Industrial Print Modules for integration in OEM Print & Apply Systems

- 400 mm/s print speeds, Ribbon Save Function, RFID UHF enabled



Applicators



APPLICATORS

Exact application of labels on products, cartons or pallets

- Can be easily mounted on our models
- Suitable for a wide range of label materials, surfaces (soft, hard, uneven, smooth), heights (constant or variable), various positions (top, bottom, side, around corners) and different conveyor speeds

Variants

LA-TO

LA-BO

LA-WO

LA-SO

LTSI / LTSA

and more...



Consumables



LABELS AND RIBBONS

Optimized match for your application

- Quality labels for all requirements: unprinted or printed, single-color or multicolor labels, with or without finishing
- Multiple materials in any size and selectable adhesive strengths
- Thermal transfer ribbons in different qualities (wax, wax-resin, resin) and colors for all common printers
- Perfect fit to all NOVEXX Solutions Hardware

Material

LABELS

RIBBONS



Service & Support



SERVICE & SUPPORT

With many years of experience, expert knowledge and enthusiasm

- Complete consulting on identification solutions
- Service-Hotline
- On-site technical service
- Service and maintenance contracts
- NOVEXX Solutions Repair Center
- NOVEXX Solutions Training Center



Label Printers

XLP 50x

The allround Label Printer for every print challenge

- Best print quality for barcodes, fonts and graphics
- 200, 300 and 600 dpi print resolution on all label materials
- Label width from 15 mm to 185 mm
- Direct thermal printing and thermal transfer printing mode
- Many options for multiple applications: knife, rewinder, applicator, dispenser
- Cut- and stack option for textile- and garment labels



64-0x

The industrial Label Printer for high volume label printing

- Print speed up to 400 mm/s
- Up to 254 mm material width
- 600 meter ribbon roll for more efficiency and uptime
- Ribbon Save Function significantly reduces ribbon consumption
- Many options for multiple applications: knife, rewinder, applicator, dispenser, RFID UHF

Models

XLP 50x

64-0x

XTP



Plug & Play Complete Solutions

XPU

The reliable Pallet Labeler for GS1 compliant pallet labels

XLA

The modular, individually configurable Labeling System for product labeling

XTD

The flexible labeling solution for top and bottom product labeling

Solutions

XPU

XLA

XTD



Data Management Software

TRACE-it

Software for central data and process management

- Central control of all print data
- Management of all labeling processes
- Interface to ERP and MES systems
- Independent of print technology and manufacturer
- Cross-site preparation of data, print templates and print jobs, intuitive user interface
- Ensuring a high level of transparency

READY TO PERFORM!

PRODUCT | CARTON | PALLET

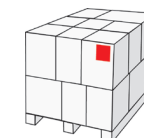
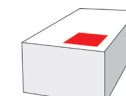
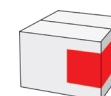
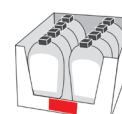



QUALITY MADE IN GERMANY

NOVEXX Solutions GmbH
Ohmstraße 3
85386 Eching/Munich | Germany

T +49 (0)8165 925-0
M solutions@novexx.com
www.novexx.com